

LAF Classic Product specifications

Countertop Unit

Dimensions with Accessories	(WxHxD) 8.77 x 22.19 x 22.14 inches 8.77 x 24.70 x 26.80 inches
Weight	59.75 lbs
Power	Fridge: 120V~; 60Hz; 1A; 1x NEMA 5-15 LAF: 120V~; 60Hz; 20A; 1x NEMA 5-20
Package Dimensions	(WxHxD) 30.7in x 13.8in x 25.8 inches
Dispense Speed	Up to 0.317 gal/min* (LAF Classic) Up to 0.423 gal/min* (LAF Classic Pro)
Water Supply	Water Treatment: Free from undissolved solids. Mechanical Filtration: 10 µm. Carbonate Hardness: ≤5°dKH. Connection: 3/8 female connector. Pressure: > 14.5 PSI < 115 PSI
Water Drainage	yes, 1x 0.24 inches drain tube
Counterspace	Leave at least 7.9 inches free space behind machine for proper ventilation and connections cutout.
Environment	Humidity: ≤80% relative humidity, no condensation Temperature: +41 °F to +95 °F

*depending on foam texture

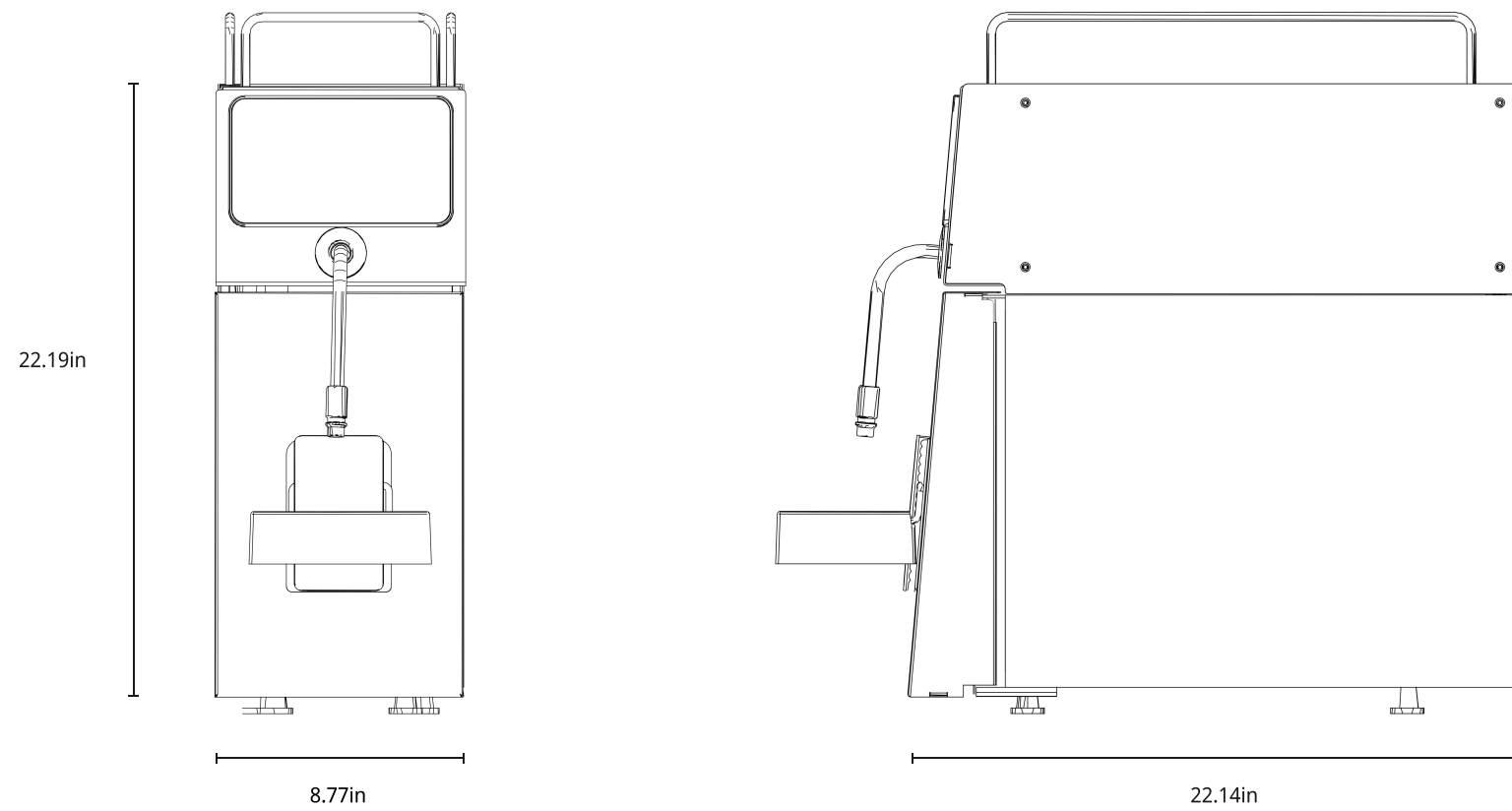

Dimensions (WxHxD): 8.77 x 22.19 x 22.14 inches and with Accessories 8.77 x 24.70 x 26.80 inches



LAF Classic – full unit on counter (including fridge)

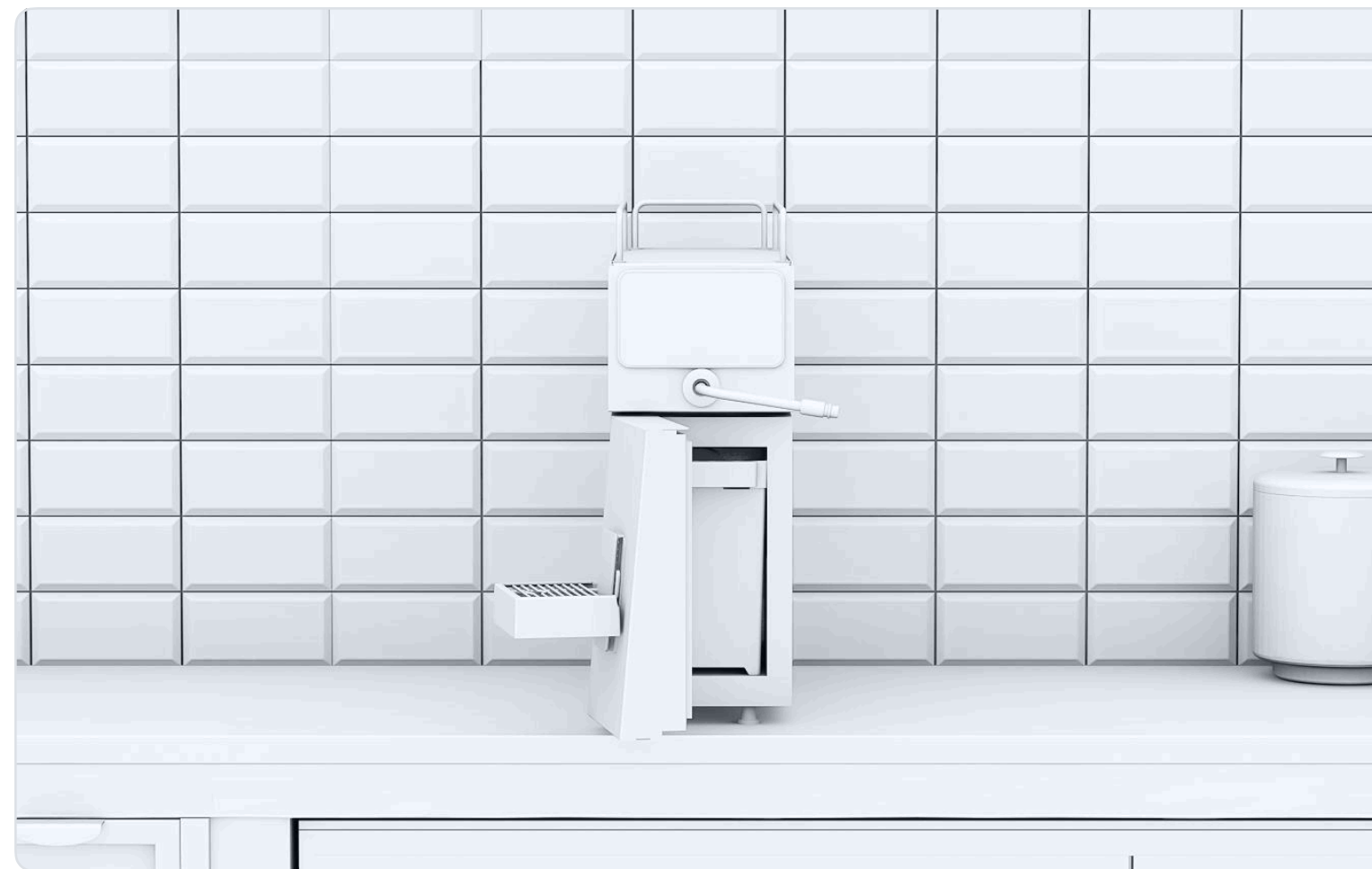

Standard fridge with 3.7L (1 gal) container



Extra fridge setup: 2x 3.7L (1 gal) containers